

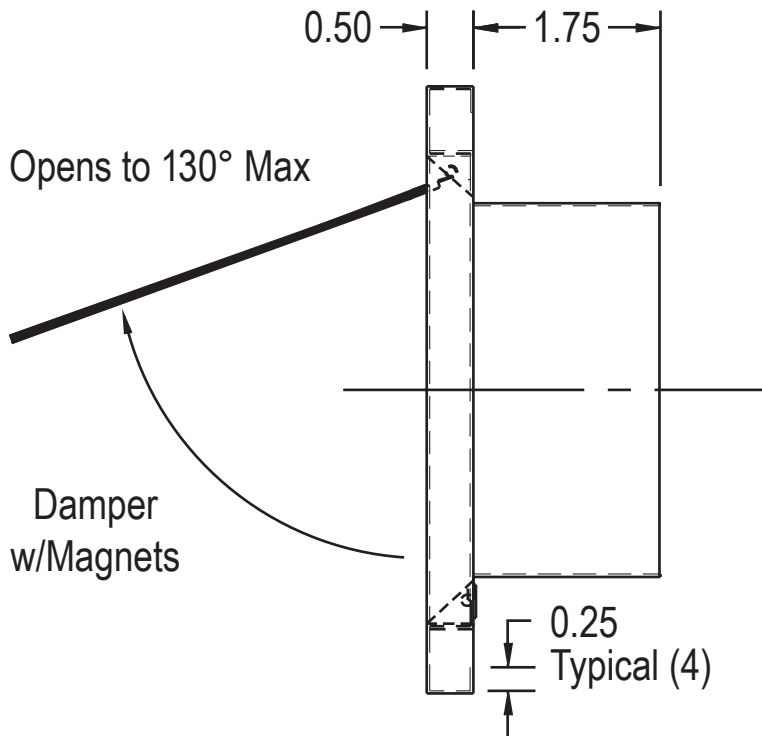

Technical Product Specifications

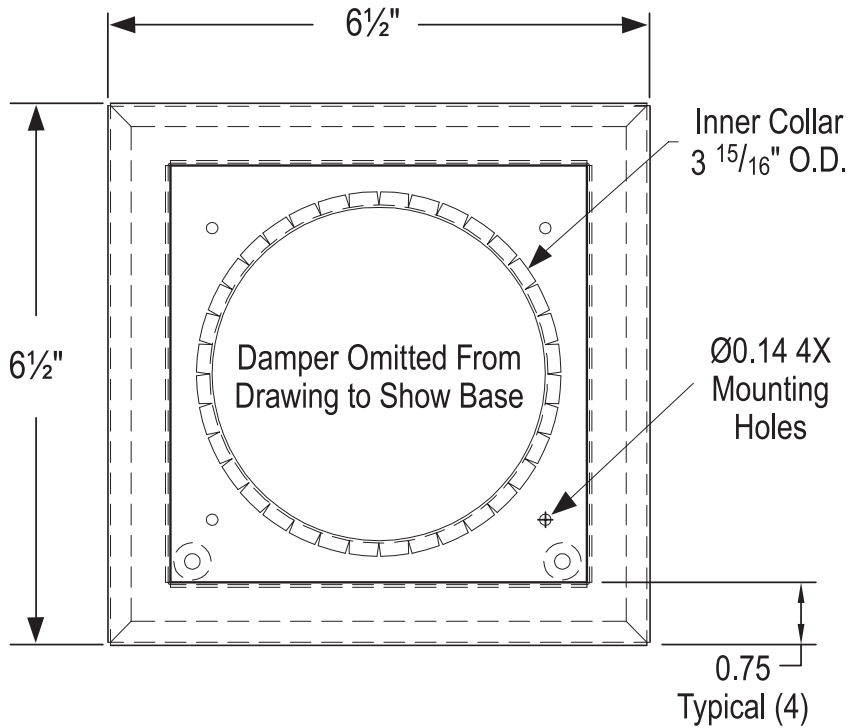

Model Number	Color
DWV4W	White
DWV4T	Tan
DWV4B	Brown

Performance Data

Product Use:

- Venting Dryer Exhaust Systems Through Exterior Walls
- Meets or Exceeds Building Code Requirements
- Complies w/ IMC 504.4 & IRC 1502.3

Materials:

- 26 Gauge Galvanized Steel Housing
- 30 Gauge Galvanized Steel Damper
- Polyester TGIC Weather Resistant Powder Coating

General Information

Benefits:

- Improves Aesthetics with Flush Installation
- Installs Easily in New and Existing Construction
- Stands the Test of Time with Durable Materials
- Simplifies Duct Cleaning with Easy Accessibility
- Deters Bird and Rodent Entry
- Operates Quietly when Opening and Closing
- Maximizes Airflow Efficiency
- Minimizes Dryer Cycle Times

Features:

- Galvanized & Powder Coated Steel Construction
- Lightweight Damper and Heavier Frame
- Damper Opens Freely to 130°
- Low Strength Closure Magnets
- Rubber Bumpers for Quiet Closing Damper
- Slightly Narrower Collar Rests within Sturdy Frame
- Four Built-in Mounting Holes
- Stocked in 3 Colors: White, Tan and Brown

Manufactured By

In-O-Vate Technologies, Inc.

810 Saturn Street, Suite 20
 Jupiter, FL 33477
 Phone: (888) 443-7937
 Fax: (561) 745-9723
www.dryerwallvent.com